



Power Assisted Bicycle

User's Manual

Model#: Austin

- Please read this users manual before using your Daymak E-bike
- Please check your e-bike before you use it.

Daymak.Com

CONTENT

- Read the following before use.....2**
- Names of parts.....3**
- Dashboard Controls..... 4**
- Hub Motor.5**
- Charging.....6**
- Battery.....7**
- Wiring Diagram.....8**
- Controller.....9**
- Handlebar Controls.....10**
- Style characteristics.....10**
- Capability.....11**

◆ Read the following before use

This section provides important information about using power assisted bicycle. Before using, be sure to read the following information.

■ About this manual

- The information contained in the manual may be subject to change without notice. For the latest information on the product names, model numbers, etc., Please consult your local Daymak dealer or franchise.
- The information contained in this manual has been compiled by taking all possible measures to ensure its accuracy. However, if you find any errors or incomplete information, please contact your local Daymak dealer or franchise.
- Daymak will not assume any liability for damages, loss of profit or claim from a third party due to improper use of this product. Daymak will not assume any liability for damages due to damage of the E-bike resulting from servicing by a third party who is not a Daymak certified dealer or franchise.

Attention

- Before using your power assisted bicycle, read this manual carefully to ensure correct use.
- Please observe all traffic regulations.
- When replacing your battery please dispose of it at a proper battery recycling facility. If you are unsure of where to find one contact your local Daymak dealer.
- Please check your e-bike before you use it.

■ Capacity

Your power assisted bicycle has a capacity of battery from 35 to 50km. This capacity varies according to various situations including but not limited to; the weight of the driver, the wind, coasting, etc.

Your dashboard console has a charge indicator. When a load is placed on the battery (acceleration) the needle will indicate the amount of charge left in the battery.

When your battery charge is becoming low, ensure you charge it as soon as possible to avoid any long-term damage.

• Suggestions

If driving for a long distance try to economize the use of your battery by coasting, avoiding stop and go movement and removing any extra luggage.

When accelerating from a stop, use the pedals to increase your acceleration. In driving, use both electric power and manpower. Avoid using the throttle while traveling down-hill, let the e-bike coast to maintain the battery charge.

MAIN PROCEEDING FOR USER

■ Circuit Breaker

The circuit breaker is situated between the battery and controller. When storing the bike for extended periods, turn it off.

If your e-bike is acting strangely, turn off the circuit breaker and bring the bike to your Daymak dealer.

The throttle is on the right side grip; rotate the handlebar inward gently to speed-up, and release to slow down.

Do not over-rotate the grip, use a steady, firm twist to accelerate. This will help increase distance and keep the battery in better operating condition.

■ Brakes

Your e-bike has front and rear brakes that are engaged using the brake levers attached to the handlebars.

When the brakes are engaged the power to the engine will be cut until the levers are released.

■ Headlight and Horn

Turn on the headlight and taillight when riding during night to ensure you are seen.

The horn's switch is on the left handlebar, to operate, depress the red button marked horn.

◆ NAMES OF PARTS



D-Front light

1- Tall light

2- Carrier

3- Back absorber

4- Saddle

5- Battery

6- Power switch and battery lock

7- Speed handlebar

8- Controller

9- Electric hooter

10- Front shock absorber

11- Front brake with power off

12- Front mudguard

13- Back mudguard

14- Rim

15- Hob motor

16- Chain guard

17- Support

18- Tire

19- Spoke

◆ Style characteristics

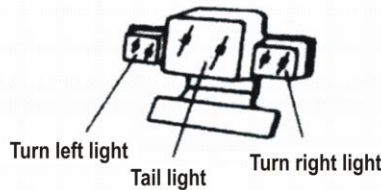
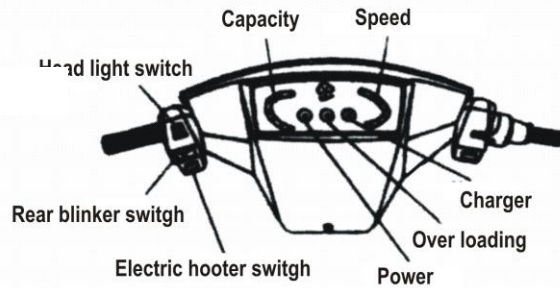
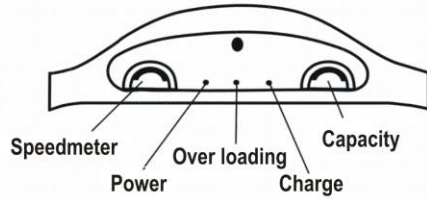
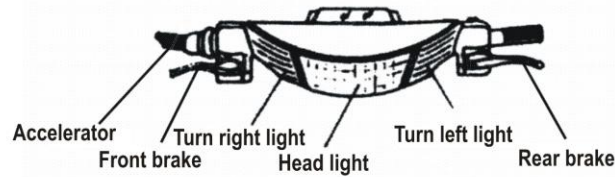

◆ MAIN TECHNICAL PARAMETER

Model	AUSTIN
Total weight	≤ 80 kg
Standard loading capacity	75 kg
Max. loading capacity	125 kg

Max. speed	32km/h		
Max Mileage	40km		
Battery type	Valve regulated and sealed lead-acid battery		
Capacity	500 Wh		
Voltage	48 V		
Hub motor	Magnetic DC motor		
Rated voltage	48 V		
Rated output power	500 W		
Max. output torque	36N.m		
Input voltage of charger	AC110V±10%/50Hz		
Output voltage of charger	43.8±0.4V		
Charger current	2.5±0.2A		

CONTROLLER

• **Controller Technical Parameter**

The controller contains the main control board, capacity board, speed handlebar, and brake handlebar.

Model	Input voltage	Low voltage protective	Excess current protective
D-125	48V	>43.5V	<17A

Functions: Stepless speed adjustment, brake power off protective, low voltage protective, excess current fuses. The controller can become warm, refrain from covering the controller as this can cause the part to overheat and fail.

Hub motor

Tech. Parameter for hub motor

The power assisted bicycle has a magnetic DC motor on the hub. This kind of motor has excellent low-end torque and high efficiency while working in this range.

Voltage	Rated rolled speed	Rated power	Working efficiency
48V	200 rpm	500W	70-80%

Motor structure

The hub motor is located in the rear wheel; features include the DC magnetic motor, speed reduction gear, speed free clutch and outer cover.

When the motor is working some noise is normal. It is also normal to experience noise in the hub motor when the e-bike is being pushed backwards.

Motor interior maintenance

Your e-bike should be brought in to your Daymak certified dealer or franchise for maintenance and service every 2000 hours.

Motor external maintenance

Before every ride check motor to ensure it is fastened to the bike properly. If the motor is loose bring the bike for service to your Daymak certified dealer.

Important advice

Daymak does not recommend riding your e-bike in the rain but if you are stuck in this situation make sure the motor is not immersed in water deeper than the tire.

5

Scheme of wiring

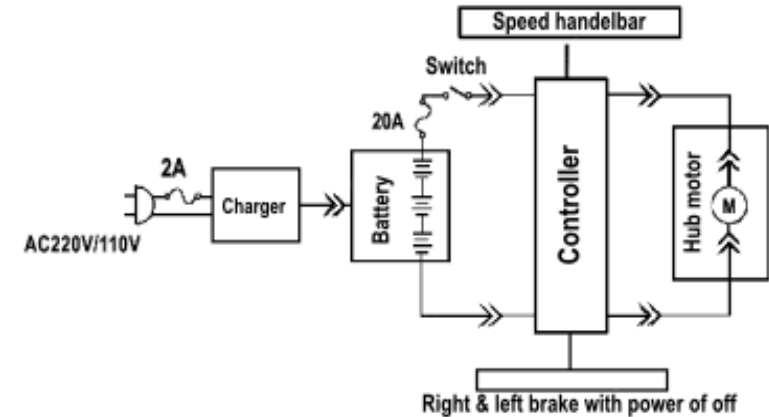

Input voltage	Power Rated	Voltage Charge	Charge current	Charge time
110V±10%	80W	43.2~44.2V	2.5A±0.02A	4-8h

Attention

If you are in an area that does not support 110V electrical systems please purchase an adapter that will convert the flow of electricity to the proper amount required by your Daymak e-bike.

- **Charging**

For optimal charging conditions, plug in your bike immediately after riding. On your charger if the indicator LED is green, the battery is full. When the charge has been completed, remove the charger from the bike and electrical supply.

- ◆ When charging your e-bike turn off the ignition. **Plug the female end into the e-bike and then plug the male end into your 110V electrical supply.** Keep the charger on a flat, cool surface while charging.
- ◆ If you are removing the battery to charge keep it face up and on a flat, cool surface. While charging do not cover it with anything.

Other important notes

- ◆ Don't touch the two metal poles in the battery box at one time to avoid short circuit damage when charging.
- ◆ When storing the charger and battery, keep them in a warm, dry environment.
- ◆ Don't leak liquid or metal filings in the charger to avoid short circuit damage.

The charger included with your e-bike will not work on any other e-bike. Do not use anything but a Daymak certified charger. Doing so can cause damage to the battery and other systems.

- **Important advice**

If the charger indicator LED doesn't change color from red for a long time (>14h) and the battery is a high temperature the charger or battery may need replacing. Stop charging and take it to your Daymak dealer or franchise.

- **BATTERY**

- Battery type: valve regulated and sealed lead-acid battery.

Battery size per piece	Weight per piece	Standard capacity	Series-Connection	Rated capacity
170*98*110mm	6 kg	12V*17AH	Four batteries	500Wh

- Charge your battery fully after riding; this will give the battery a longer service life. If you are not using the battery for a long period of time, charge it at least once a week.

MTO Pilot Project Restrictions

Effective October 3, 2006, the Province of Ontario began a three-year pilot project to evaluate the use of power-assisted bicycles (also known as electric bikes or e-bikes) on roads and highways where conventional bicycles are currently allowed. The pilot is opened to all Ontarians 16 years of age and older and will run for three years. For the duration of the pilot, electric bicycles will be treated as bicycles and must follow the same rules of the road as set out in the Highway Traffic Act that currently apply to cyclists.

There are two exceptions:

- **Operators must be 16 years of age or older, and**
- **All operators must wear an approved bicycle helmet at all times.**

During the pilot:

- No driver's license is required,
- No written test is required,
- No vehicle registration or plate required,
- No requirement for motor vehicle liability insurance.

An e-bike is a bike that:

- has steering handlebars and is equipped with pedals;
- is designed to be propelled primarily by muscular power and to travel on not more than three wheels;
- has one or more electric motors that have, singly or in combination, a power output rating of 500W or less. (Note: the motor is electric, and is incapable of propelling the cycle at speed of 32 km/h or greater on level ground, without pedaling); and

- bears a permanently affixed label by the manufacturer stating in both official languages that the vehicle conforms to the federal definition of a power-assisted bicycle.

The power-assisted bicycle pilot is authorized by Ontario Regulation 473/06. In this regulation, the legal definition of an e-bike refers to the federal definition of a power-assisted bicycle. For the full definition, please see subsection 2(1) of the Motor Vehicle Safety Regulations under the Motor Vehicle Safety Act.

TPS Training Bulletin

Attention Traffic and Training Sergeants:

Recently we have had some enquiries from officers in the field and members of the public regard e-bikes and some confusion over the definition of a Power Assisted Bicycle (e-bike)

According to Ontario Regulation 473/06 an e-bike that meets the definition is deemed not to be a motor vehicle, under the Highway Traffic Act, and is essentially treated as a bicycle. Any person 16 years and over who wears a bicycle helmet as required by subsection 104 (2.1) of the HTA may ride a power assisted bicycle on the highway. There is no requirement for drivers license, permit or insurance.

The main requirements of a "power assisted bicycle" is that it "is capable of being propelled by muscular power" and a "bears a label that is permanently affixed by the manufacturer stating that the vehicle is a power assisted bicycle". Obviously while the e-bike is being operated on the road, the pedals must be attached and functional.

O. Reg 473 refers to federal Motor Vehicle Safety Regulations for a definition.

Rick Line, TC 4365,
TPS Training & Education Unit,
Traffic & Provincial Statutes Section,
C.O. Bick College,
4620 Finch Ave. E.,
Scarborough, On, M1S-4G2
Ph: 416-808-4877
"Committed to Lifelong Learning"